

The publication was co-financed by the 2007–2013 IPA Adriatic Cross-Border Cooperation Programme. The publisher DUNEA and the editor Park Škocjanske jame are solely responsible for the contents of the publication. The contents of the publication do not necessarily reflect the official position of the European Union.

COMMON GUIDELINES AND RECOMMENDATIONS FOR CHANGING LEGISLATION

COMMON GUIDELINES AND RECOMMENDATIONS FOR CHANGING LEGISLATION

Project Partners:



rerasd



Associated Partners:



REGIONE DEL VENETO

Published by: DUNEIA

Edited by: Karmen Peternejl, Park Škofjanske jame

Authors (in alphabetical order): Sanja Alaber, Miloš Bavec, Sara Biolchi, Stefano Devoto, Stefano Furlani, Goran Glamuzina, Jernej Jež, Tvrtko Korbar, Maja Oven Stanič, Karmen Peternejl, Fabiana Pieri, Duška Rokavec, Ivan Stanič, Domen Zupančič

Photographs: Ladislav Fuček, Goran Glamuzina, Jaro Ješe, Jernej Jež, Bogdan Jurkovšek, Dubravko Matičec, Karmen Peternejl, Domen Zupančič

Cartography: Matija Krivic

Language review and translation: Abecednik

Design and printing: Alfa-2 d.o.o.

Print run: 100

Place and date of publishing: Dubrovnik, October, 2015

The use of platy limestone as a traditional building material has been preserved to the present day and it gives a special character to the eastern Adriatic coast.

It is, however, apparent that no clear-cut guidelines have been established in the area of spatial planning, town planning, construction and the preservation of natural and cultural heritage for the sustainable exploitation and use of this stone as a building material and neither have such guidelines been established for its conservation as a valuable natural feature or for the preservation of buildings and materials that represent cultural heritage. Building stone is thus often used in an inappropriate manner and stone deposit sites and the characteristic stone architectural elements of buildings are damaged or even destroyed.

The present document aims first and foremost to provide information for owners of buildings that have platy limestone built into them and to investors wishing to use this natural stone; either as roof tiles, as courtyard pavers, for window sills or other construction elements, for the construction of stone houses or the erection of dry-stone walls. We wish to encourage owners (irrespective of whether their building has been formally granted the status of cultural heritage or not) to manage the inheritance left to them by their ancestors responsibly and to strive to preserve it for future generations. (Future) investors all too frequently encounter obstacles at the very start, i.e. when they decide to carry out a particular intervention on a building such as regular maintenance, renovation, restoration or perhaps even the construction of a new building. Many find it hard to navigate through the complicated procedures, are not aware of all of the restrictions that they could encounter even before initiating the investment or during it. Furthermore, the knowledge of the correct use of platy limestone as a building material is being lost with the ever decreasing use of the stone.

Despite being drafted in a popular or non-technical manner, the present guidelines and common recommendations are intended for the profes-

sional public as well. We especially wish to address and caution the representatives of ministries, regional or local governments and the institutions tasked with the protection of natural and cultural heritage – i.e. anyone who is in any way involved in the decision-making process. We want to draw attention to the urgency of the amendment of legislation in the area of the extraction and use of platy limestone as a building material if we wish to preserve, renovate and maintain buildings (cultural heritage) with platy limestone built in.

The document is drafted in a way that guides the user systematically through the entire investment process. The first chapter presents the potential restrictions that must be observed. Most of the restrictions relate to the geographical location of the building; these restrictions include Natura 2000 sites, ecologically important areas, individual protected areas or other restrictions in areas of natural heritage. Each of these restrictions feature a brief description of the process for the acquisition of permits and the institution competent for issuing such permits. This is followed by recommendations and guidelines for the sustainable extraction of platy limestone as a building material. It is possible to come across various fossils when extracting the material or when renovating buildings. We also describe the procedure to be followed if fossils are discovered, who to contact and what such a fossil find means for the course of the investment. Perhaps the most important chapter for an investor is the one summarising the general architectural solutions for buildings with platy limestone built in and the guidelines for the correct integration of this stone into buildings.

The final chapter is first and foremost intended for the policy-makers who have the opportunity and leverage allowing them to amend the existing rules, instructions, guidelines and restrictions. We have prepared a concrete proposal for legislative amendments that are urgently needed if we wish to preserve heritage in the future. This will not be possible if legislation remains rigid and if it does not allow owners and potential investors to legally obtain the bases for the maintenance, renovation or reconstruction of individual buildings, i.e. the required building material, which in our case is platy limestone.

1. POSSIBLE LIMITATIONS ON THE RECONSTRUCTION OF MY HOUSE

Limitations from a natural heritage point of view depend on the location of the house/object (the location of valuable natural features, fossils as natural valuable features, protected areas, ecologically important areas or special protected areas – Natura 2000 sites). General guidelines or prohibitions are regulated by law, while further restrictions are determined in the process of obtaining permits.

Several restrictions may apply in certain building locations. The maps below show the restrictions in the area of natural heritage protection in individual countries. In addition to natural heritage, one must also observe cultural heritage as many buildings (and areas) are protected as cultural monuments of local or national importance.

The matrix below shows the restrictions in the area of natural heritage protection in an individual country, the scope of such restrictions and what they mean for a future investor, as well as the permits (including the procedure for obtaining such permits and the institution competent for issuing them) that an investor must obtain prior to commencing renovation, conservation, restoration or construction.

When performing interventions in a building or area that is protected as cultural heritage of local or national importance or that is registered in the cultural heritage register, which involves more than just maintenance, it is necessary to inform the competent conservator thereof. The list of buildings or areas with different levels of protection is provided in

the cultural heritage register. The general guidelines for the conservation of monuments of local or national importance are provided in decrees or laws protecting cultural heritage. If, however, interventions into cultural heritage recorded in the register are envisaged, then the cultural protection conditions and cultural protection consent prescribed by the competent conservator need to be obtained beforehand. As the registers are updated and supplemented regularly, the currently valid lists of protected heritage can be found at the following websites:

SLOVENIA: [Cultural heritage register](#) (managed by the Ministry of Culture of the Republic of Slovenia)

CROATIA: [Cultural heritage register](#) (managed by the Ministry of Culture of the Republic of Croatia)

ITALY: there is no official register; useful information can be obtained at: [Regional cultural heritage information system](#) (managed by the Autonomous Region of Friuli Venezia Giulia)

BOSNIA AND HERZEGOVINA: there is no national-level official register of cultural heritage; data for the West Herzegovina Canton can be obtained at the [Ministry of Education, Science, Culture and Sport](#).

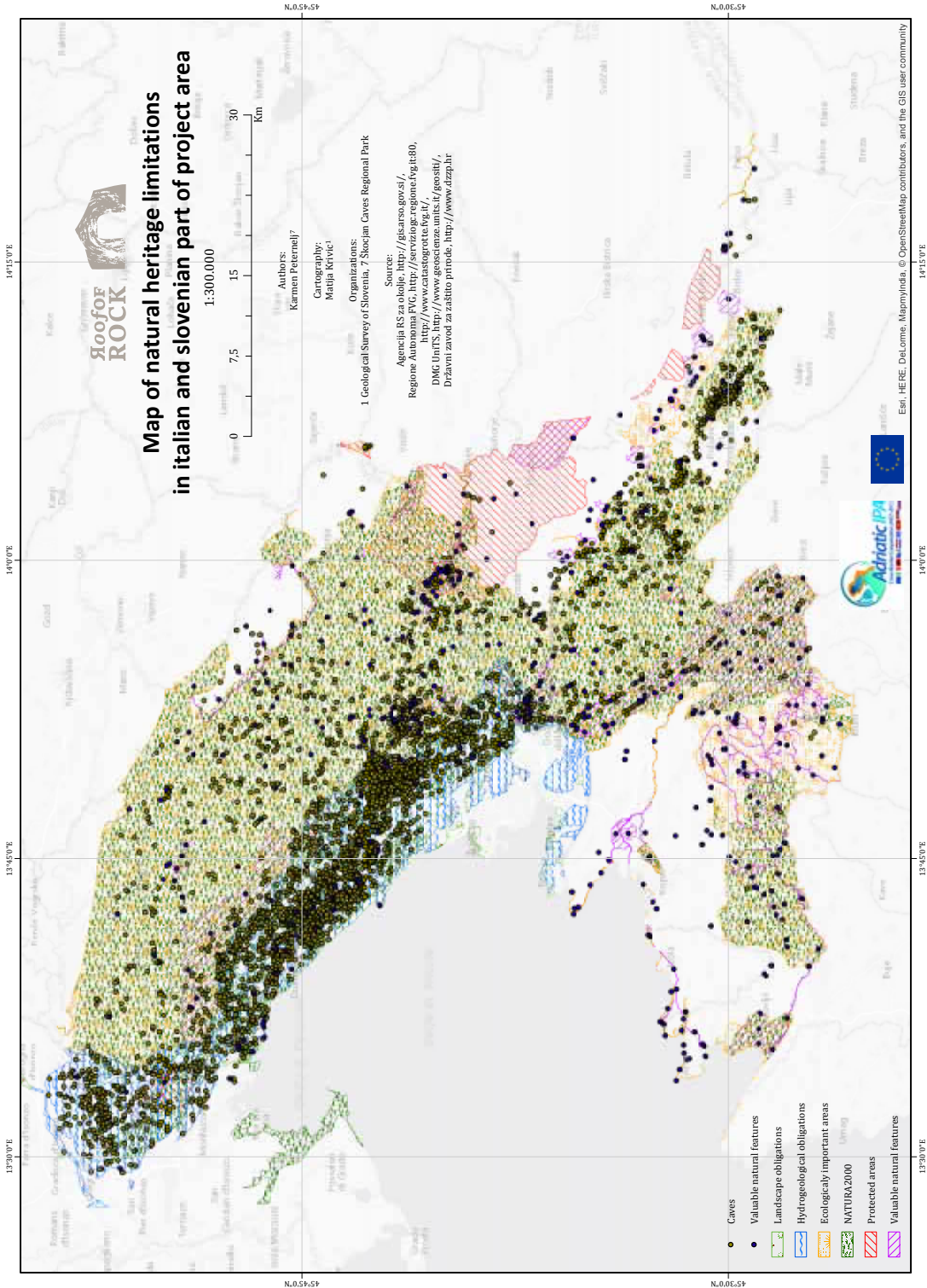

Map 1: Presentation of restrictions in the area of natural heritage in the Slovenian and Italian parts of the project area

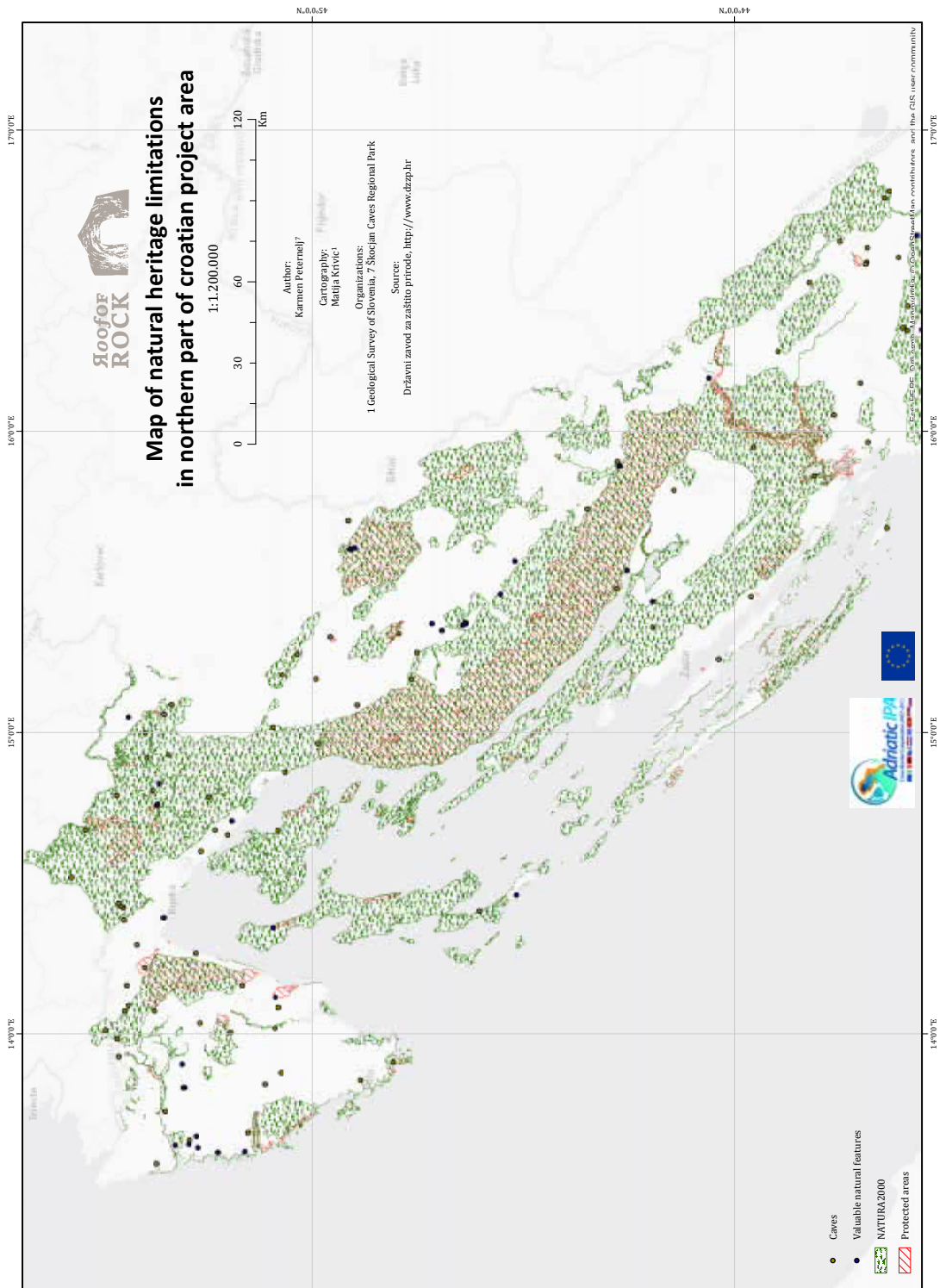

Map of natural heritage limitations in northern part of croatian project area



1:1.200.000

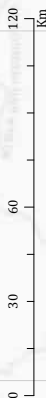

Author:
Kamen Peteršelj

Cartography:
Maja Krivic

Organizations:
1 Geological Survey of Slovenia, 7 Škočjan Caves Regional Park

Source:
Državni zavod za zaštitu prirode, <http://www.dzafp.hr>

- Caves
- Valuable natural features
- NATURA2000
- Protected areas



This map is a derivative work of the data provided by the user community.

Map 2: Presentation of restrictions in the area of natural heritage in the northern part of the Croatian project area

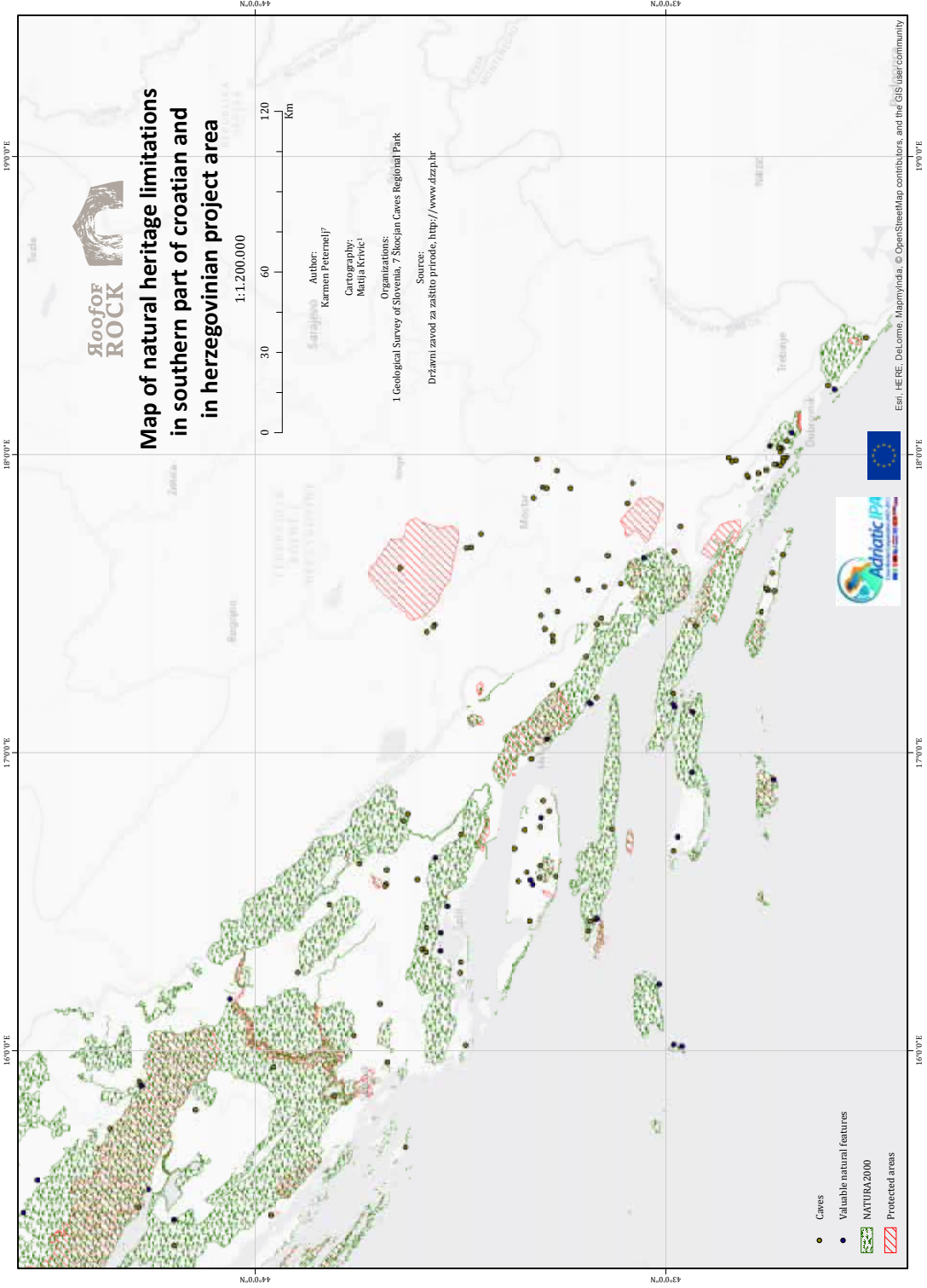

Map 3: Presentation of restrictions in the area of natural heritage in the southern part of the Croatian and Herzegovina portions of the project area

NAME OF LIMITATION	COUNTRY	DESCRIPTION OF LIMITATION	REQUIRED PERMITS FOR THE RECONSTRUCTION OF AN OBJECT	HOW TO GET THESE PERMITS	RESPONSIBLE INSTITUTION	LEGISLATION
NATURA 2000	SLOVENIA		<p>To get a building permit in a Nature 2000 area, nature protection conditions and a nature protection consent have to be obtained.</p> <p>In addition, certain activities affecting the environment require an assessment of environmental impact and the issuance of environmental protection consent to grant a building permit.</p>	<p>The application to obtain nature protection conditions and a nature protection consent must be sent to the Slovenian Environment Agency.</p>	Slovenian Environment Agency	<p>Uredba o posebnih varstvenih območjih Zakon o ohranjanju narave Zakon o varstvu okolja</p>
NATURA 2000	ITALY	<p>A European network of protected sites with the primary objective of preserving biodiversity. Those areas are intended for the conservation of flora, fauna and habitats that are rare or endangered due to human activities.</p>	<p>The assessment of the activities affecting nature has to be carried out before issuing planning information or prior to issuing a permit for conducting any activities. According to the Decree in the FVG Region, some interventions related to the exercise of agro-forestry-pastoral activities may be excluded from the assessment of activities affecting nature.</p>	<p>A nature protection consent must also be obtained in cases of constructing a simple object, when a building permit does not need to be obtained, as far as is specified in the regulations for nature conservation. In the FVG Region, it is obtained from the Forestry Regional Administration.</p>	Service environmental assessments of the FVG Region. Inspectorate for the Agriculture and Forestry Agency, FVG Region.	<p>Decreto Pres. 8th Sept. 1997, no. 357 Decreto of the Regional Council 13223/2014</p>
	CROATIA		<p>Building/(re)construction permit from the administrative department in the county or city responsible for regional planning and construction.</p>	<p>The application for a building permit is submitted to the administrative department in the county or city responsible for regional planning and construction; if the house is in the construction zone according to a valid Physical Plan that passed appropriate assessment for the Ecological network, it is not necessary to request an appropriate assessment; if not, it is important to pass an appropriate assessment carried out by the Ministry of the Environment and Nature Protection and State Institute for Nature Protection provides prior expert advice in the procedure.</p>	<p>Ministry of the Environment and Nature Protection and the State Institute for Nature Protection, which provides previous expert advice.</p>	<p>Nature Protection Act Ordinance on the Appropriate Assessment for the Ecological Network</p>

NAME OF LIMITATION	COUNTRY	DESCRIPTION OF LIMITATION	REQUIRED PERMITS FOR THE RECONSTRUCTION OF AN OBJECT	HOW TO GET THESE PERMITS	RESPONSIBLE INSTITUTION	LEGISLATION
PROTECTED AREAS	SLOVENIA	The Škocjan Caves Park was established with the aim of preserving exceptional geomorphological, geological, hydrological, paleontological and archaeological sites.	In the territory of two settlement monuments, Škocjan and Betanija, buildings should be renewed in the traditional style, according to the standing planning document, as well as the conservation guidelines.	The application to obtain cultural heritage specifications and a cultural heritage agreement must be sent to the competent regional office of the Institute for the Protection of Cultural Heritage of Slovenia (IPCHS).	competent regional office of the IPCHS.	Škocjan Caves Regional Park Act
	ITALY	Carrying out activities in protected areas is permitted if they do not cause any negative influence.	The basis for affecting the natural environment or carrying-out activities is a permit, which is issued by the regional superintendence. Cutting crops, forestry, reforestation, land recovery, fire protection and conservation can be carried out after a anticipation or authorization from the FVG Region.	A private entity gets a permit issued by the regional superintendence; a public institution gets a permit issued by the FVG region. Cutting crops, forestry, reforestation, land recovery, fire protection and conservation can be carried out after a anticipation or authorization from the FVG Region.	FVG Region: Central management for agricultural, natural, forestry resources and mountains. FVG Cultural Heritage Authority	FVG Regional law 30 september 1986, no. 42, article 49
	CROATIA	In Croatia there are 8 national and 11 nature parks. They were established with the aim of protecting natural and cultural elements, rare animals and some specific sites.	Building permit (building or reconstruction) All national parks and nature parks are also part of the ecological network- if a project may have adverse effects on the conservation objectives and integrity of the ecological network, it is necessary to carry out a prior evaluation of the ecological network.	The application for a building permit is submitted to the administrative department in the county or city responsible for regional planning and construction. If the house is in the construction zone according to the valid Physical Plan request, an appropriate assessment is not necessary, if not, it is necessary to carry out the prior evaluation of the ecological network, which is done by the Ministry of the Environment and Nature Protection, while the State Institute for Nature Protection provides expert advice.	Administrative department in the county or city responsible for regional planning and construction. Ministry of the Environment and Nature Protection	Nature protection Act Ordinance on the Appropriate Assessment for the Ecological Network acts and Spatial plans of each protected areas
BOSNIA and HERZEGOVINA	Parks were established with the aim of protecting specific natural and cultural elements in the mountain area.	The use of a protected area must follow the principles of sustainable development and is directed towards the interests and needs of local inhabitants. All activities require the permission and consent of the administration of the park and the relevant in situations.	All requests are dealt with by the founder of protected area, namely by the Ministry of Tourism, Trade and Environmental Protection in each County, with the consent of the Park Administration.	Ministry of Tourism, Trade and Environmental Protection in each County	Nature Park Hutovo Blato Act Nature Park Bliđinje Act	

NAME OF LIMITATION	COUNTRY	DESCRIPTION OF LIMITATION	REQUIRED PERMITS FOR THE RE-CONSTRUCTION OF AN OBJECT	HOW TO GET THESE PERMITS	RESPONSIBLE INSTITUTION	LEGISLATION
OTHER LIMITATIONS	SLOVENIA	Ecologically important areas recognized as the most valuable and most important for maintaining biodiversity. They include habitats of endangered flora and fauna, relevant animal migration routes, areas important for ensuring the connectivity of populations and the entire Natura 2000 area.	No nature conservation consent is needed for these areas.	/	/	Decree on ecologically important areas
	ITALY	Carrying out activities in areas of landscape interest is permitted if they do not cause any negative influence. The owners of property in areas of landscape interest, protected by the law, cannot destroy them, nor introduce changes that adversely affect the landscape values given protection.	The basis for carrying-out activities is a permit issued by the regional superintendence. Cutting crops, forestry, reforestation, land recovery, fire protection and conservation can be carried out after an anticipation or authorization from the FVG Region.	A private entity gets a permit issued by the regional superintendence, while a public institution gets it from the FVG region. Activities can be carried out after an anticipation or authorization from the FVG Region. Nature protection consent: Inspectorate for the Agriculture and Forestry Agency.	FVG Region, Central management for agricultural, natural, forestry resources and mountains, service for protecting natural habitats and wildlife.	Legislative Decree 22 January 2004
		Carrying out activities in areas with hydrogeological constraints is permitted if they do not cause any negative influence.	The basis for carrying-out activities is a permit issued by the Regions.	The permit is issued by the FVG Region and contains all the requirements designed to prevent and mitigate land damage.	Inspectorate for the Agriculture and Forestry Agency of the FVG Region	Royal Decree 30 December 1923, No. 3267 FVG Regional law 23 April 2007, no. 9
	CROATIA	A natural monument is an individual unmodified part of nature that has ecological, scientific, aesthetic and educational value.	A building permit is needed.	An application for a building permit is submitted to the administrative department in the county or city responsible for regional planning and construction. The deadline to obtain the building permit is 30 days.	Administrative department in the county or city responsible for regional planning and construction.	Nature protection Act Spatial plan of county, municipality, city etc.
	A significant landscape is a natural or cultivated area of great landscape value with biodiversity and/or geodiversity or a landscape of preserved unique features characteristic of the particular area.	A building permit is needed. If a project may have adverse effects on the conservation objectives and integrity of the ecological network, it is necessary to carry out the prior evaluation of the project on an ecological network.				

NAME OF LIMITATION	COUNTRY	DESCRIPTION OF LIMITATION	REQUIRED PERMITS FOR THE RECONSTRUCTION OF AN OBJECT	HOW TO GET THESE PERMITS	RESPONSIBLE INSTITUTION	LEGISLATION
	SLOVENIA	Valuable natural features are defined as rare, valuable or well-known natural phenomena, parts of living or non-living nature, nature areas, ecosystems and landscapes.	Valuable natural features are defined as rare, valuable or well-known natural phenomena, parts of living or non-living nature, nature areas, ecosystems and landscapes.	A person who wishes to build in an area of valuable natural features has to obtain nature protection conditions and a nature protection consent for the building permit to be granted. A nature protection consent must also be obtained in cases of constructing a simple object, when a building permit does not need to be obtained.	Nature protection conditions and a nature protection consent are issued by the Slovenian Environment Agency.	Decree on the categories of valuable natural features Rules on the designation and protection of valuable natural
NATURAL VALUABLE FEATURES	ITALY	Minerals have the status of "landscape assets" and "statally available heritage". The act of taking minerals and fossils is absolutely prohibited, except with permission granted for scientific reasons.	Only activities connected to scientific research are admitted.	The permit is issued by the regional superintendence.	FVG Cultural Heritage Authority	Legislative Decree 22 January 2004
	CROATIA	The natural monument is an individual unmodified part of nature that has an ecological, scientific, aesthetic or educational value. Procedures and activities are allowed that do not threaten its features and values.	Building permit (construction or reconstruction); usually these are small parts of nature (trees, caves, etc.) where it is not permitted to build because the natural values are threatened.	The application for a building permit is submitted to the administrative department in the county or city responsible for regional planning and construction. The deadline for obtaining the building permit is 30 days.	Administrative department in the county or city responsible for regional planning and construction.	Nature protection Act Spatial plans of county, municipality, city etc.

2. RECOMMENDATIONS AND GUIDELINES FOR THE SUSTAINABLE EXPLOITATION OF PLATY LIMESTONE

Detailed geological investigation of the platy limestone revealed a widespread occurrence in the RoofOfRock project area along the karstified Adriatic coast. At many locations, limestone plates are of good quality and assessed as appropriate for use as building material. Besides, platy limestone was traditionally exploited extensively for local use, and there are many examples of good practice of its usage. Despite the fact that almost all platy limestone types were deposited on the same former (mostly Late Cretaceous and Late Paleogene) shallow-marine carbonate platform, local geological and geomorphological conditions have resulted in some important differences between the various types of platy limestone. Geological units containing platy limestone in the project area are irregularly distributed within the carbonate succession and are of different ages. Most horizons are up to a few tens of meters thick, while in many places their thickness is less than one meter. In addition, the spatial distribution of platy limestone depends significantly on the relation between geological (bedding dip) and morphological (slope dip) features. In the areas where the dip of limestone beds is gentle and the surface is relatively flat, platy limestone can be exposed over wide areas. The most spatially extensive types of platy limestone are known from the central and southwestern parts of the project area in Herzegovina, in the central Dalmatian islands (Šolta, Brač, Hvar and Korčula), the Pelješac peninsula, the Trogir and Benkovac areas as well as in western part of Istria in Croatia and in central

part of the Kras area in Slovenia, respectively. Platy limestone outcrops were also evidenced at numerous other locations where it is exposed in thin, dispersed and spatially limited horizons (e.g. the Karst area in Italy). Regarding the platy limestone quality, it should be noted that most of the platy limestone outcrops and even single beds are not lithologically homogenous, as a result of its genesis in the paleo environment. Geomechanical analyses and expert field geological assessment of the limestone quality revealed that the homogenous very fine-grained limestone (micritic lithotypes) and horizontally laminated (microbial) muddy limestone is the best quality. It is worth mentioning that in the southern and central part of the Kras in Slovenia, a special type of limestone plates of relatively good quality was widely used for roofing. It was referred to as fractured limestone as its origin is tectonically related.

The use of platy limestone as a building material has been following the rule of using the closest source possible. Plates used in constructions mostly originate from local sources, situated in the vicinity.

According to all the mentioned spatial and natural characteristics (e.g. occurrence, quality and reserves) and the traditional use of limestone plates, a set of geological recommendations and guidelines is suggested. The project area is vast and geologically, morphologically and climatically diverse so some of the recommendations can't be applied across the entire project area. Instead, certain recommendations are only applicable within selected regions. The four most prominent geological sets of recommendations for the sustainable exploitation of platy limestone are listed below.

2.1. USE OF PLATY LIMESTONE FROM ACTIVE QUARRIES

Following the Mining Acts and related regulations in all four countries, the procedure for the legal exploitation of natural stone, including platy limestone, is rather complex. For example, in Croatia there is a special restriction on all kinds of mining activities on most of the islands where platy limestone occurs extensively. In Bosnia and Herzegovina, laws and regulations related to the commercial exploitation of mineral resources are not well defined. The consequences are clearly visible in the field, particularly in the appearance of a number of small local illegal quarries.

Possible future use of limestone slabs for reconstructions or in new build-

ings could be based on the excavation of material from currently active quarries. This solution is possible for the wider area of Zadar where Benkovac platy limestone (“Benkovac Stone”) has been widely used. The stone is still commercially exploited in the quarries near Benkovac (Fig. 1). Debelo brdo and Benkovac platy limestone types are of excellent quality, as the stone is mostly densely packed micrite and fine-grained calcarenite.

Since there are no other legal platy limestone quarries in the project region of Croatia, there is a general trend of using Benkovac platy limestone in the wider area of Dalmatia, as well as in the interior of the country. Geologists propose a restriction on the use of Benkovac platy limestone (“Benkovac Stone”) just as far as the hinterland of Zadar, and not all over Dalmatia as is the case at the moment. The Benkovac stone has a yellowish colour which differs from other (mostly Cretaceous) greyish lithotypes of platy limestone that characterize other parts of the project area in Croatia. Therefore, in other parts of Dalmatia it would be more appropriate to use an autochthonous material if available.

Figure 1.
Benkovac platy limestone
quarry, Dalmatia, Croatia



In the project area of Bosnia and Herzegovina, the commercial exploitation of high-quality platy limestone is possible in active quarries at Podveležje, Raška gora, Vrđi and Zvirovići (Fig. 2). Platy limestone quality and quantity is estimated as having *potential* at all localities (following the threefold classification applied in this project, which classifies the use potential of stone according to its occurrence and quality to *no potential*, *potential*, and *high potential*). With the aim of following the traditional use of very local stone from the near vicinity of houses, the exploitation of limestone from the nearest quarries is recommended.



Figure 2.
Active quarry of platy limestone at Zvírovići 1 locality, Bosnia and Herzegovina

In other parts of the project area there are no legal commercial quarries of platy limestone.

2.2. LIMITED USE OF STONE FROM ABANDONED QUARRIES FOR THE RENOVATION OF LOCAL HOUSES

Given the complex procedure for the legal exploitation of natural stone (limestone and other rock intended for sculptures and architectural design or construction in the form of monoliths, decorative architectural stone and naturally broken quarried stone) and the fact that many regions are under special restriction for all kinds of mining activities, geologists recommend some exceptions in the permitting procedures.

Over the entire RoofOfRock project area, platy limestone was traditionally exploited for local use. Many abandoned quarries were evidenced, as well as many examples of good practice in local limestone use. Due to the large spatial distribution, quality and reserves of this building stone, the possibility for the further exploitation of platy limestone in many regions in the project area (e.g. the Kras in Slovenia, western Istria (Fig. 3), middle Dalmatia and Herzegovina) is estimated as having *potential*. Therefore, traditional local use is recommended following restricted and controlled exploitation. In each region where the need for the renovation of tradi-

tional houses appears, we propose re-opening one abandoned quarry of platy limestone. The exploitation should be restricted to the renovation of local traditional architecture and under the control of (at least local) authorities and with strict monitoring of fossil findings.

Geological conditions allow the opening of such a quarry in almost all the studied project areas with the exception of the project area in Italy. For this area, limestone plates could be provided from the adjacent Kras area in Slovenia.

Figure 3.
Abandoned quarry of platy
limestone, Istria, Croatia



2.3. STONE-GATHERING ON THE SURFACE WITH HAND TOOLS

In the project area, quality platy limestone is found at many localities. In the past, people excavated stone plates without a significant impact on the natural environment, mostly using traditional stone gathering (in Croatian: *branje kamena*) (Fig. 4). Although the so-called traditional simple “stone-gathering“ from the surface is not allowed today (anywhere in the project area), we generally recommend gathering limestone plates using simple hand tools (without machines) for the renovation of existing traditional houses and other objects. We suggest the legalization of this traditional activity on the owners’ property under the control of at least the local government.



Figure 4.
The traditional gathering
of limestone plates on a
surface



The traditional gathering of limestone plates from the surface is easy in regions where soil layer is absent or thin. Thus, the Middle Dalmatian coastal areas and islands, parts of Istria and Herzegovina are suitable for this type of building material collection. On the other hand, in the Kras or partly in Istria, the stone can't be gathered without impacting the sensitive natural environment since the rocks are covered by a layer of soil. In these regions, an appropriate amount of limestone plates can only be gathered by removing soil over a large area.

2.4. THE USE OF FRACTURED LIMESTONE FROM AN ACTIVE LEGAL QUARRY IN THE KRAS AREA

A review of the use of limestone plates as architectural building material revealed that in the southern part of the Kras in Slovenia especially, a particular type of limestone plates were used for roofing. According to geological definitions, this type of limestone is not classified as platy limestone as its platy appearance is not related to its genesis (processes of deposition and diagenesis) but is of tectonic origin. Dense systems of parallel tectonic fissures/fractures enable the excavation of thin, 3 – 10 cm thick, high-quality limestone plates (Fig. 5). This type of limestone plates were excavated in the limestone sequences of the Repen and Lipica Formation.

The rudist bioclastic limestone plates of Repen Formation were used for roofing in a wide area of the southern Kras. They were excavated in a narrow belt of the Repen Formation where abandoned quarries were also evidenced in the framework of this project. In central Kras area, fractured limestone from the Lipica Formation was also locally used for roofing.

As a possible option for the acquisition of relatively good quality limestone plates, we propose the excavation of fractured Repen limestone in the Repen Formation. This type of limestone is exposed in a wide belt between Divača and Sežana. The most perspective location is the active Griža (Tavčar) quarry near Povir.

Figure 5.
Fractured Repen limestone
in the quarry Griža pri
Povirju (Tavčar), Kras,
Slovenia



It should be noted that this stone occurs in a relatively limited area of the southern Kras. Quarrying limestone plates along fractures, even with modern equipment in an active quarry, could be a complex, time-consuming and expensive process and therefore only a limited amount of plates for renovation of roofs can be acquired with this technology.

Four main sets of geological recommendations and guidelines on the acquisition of appropriate limestone plates useful as building material are suggested:

- the use of platy limestone from active commercial quarries
- limited use of stone from abandoned quarries for the renovation of local buildings
- stone-gathering on the surface with hand tools
- the use of fractured limestone from an active commercial quarry in the Kras area

The first option is possible for the land area of Zadar County and selected parts of Herzegovina where legal active quarries exist. The second proposal covers almost the entire studied project area where abandoned quarries of quality platy limestone can be found. The third option is based on the most traditional methods of exploitation and can be suggested for areas without soil, where limited stone-gathering on the surface would not significantly impact the environment. The use of fractured limestone as a fourth option can only be proposed for a limited area of the Slovenia Karst.

3. THE EXPLOITATION OF PLATY LIMESTONE FROM THE PERSPECTIVE OF NATURAL HERITAGE PROTECTION

Having analysed the conflicts between exploitation activities and natural heritage preservation demands, we are proposing guidelines for future mitigation. They are addressed to both existing and potential future quarrying sites.

The recent increase in the demand for platy limestone materials for building restoration in the entire eligible project area has led to a strong demand for building materials for construction purposes. Hence, the need to assess the sites for natural heritage and economic suitability is increasingly important.

All member countries have some form of hierarchical government structure, with the national government at the apex and the legal and administrative structures following the “cascade” principle, i.e. regional, county and local law and practices, which are consistent with national and, especially, European ones.

The negative impacts of platy limestone exploitation are associated with deforestation, changes in hydrological or hydrogeological conditions and quality, landscape and habitat transformations that promote invasive species colonization, noise and vibration, etc. However, large portions of the eligible areas are protected by different European, National and Regional laws.

Possible limitations for the extraction of the platy limestone in the project area concern:

- the exploitation of platy limestone may have a negative impact on nature (e.g. extermination of species and habitat types that affect the integrity of the ecological network, the defacement of the natural landscape, the depletion of the natural resource, etc.);
- during the exploitation of platy limestone, valuable and rare fossils or minerals as well as speleological objects that are important from the nature heritage point of view could be found;

For non-commercial purposes, it could be useful to exploit platy limestone in some pre-determined sites and in a certain volume, without getting mining rights. All exploitation areas with mining rights are obligated to provide an Environmental Assessment to avoid any possible impact on the environment.

The use of non-autochthonous (outside the Dinaric Karst area) platy limestone has been absolutely unacceptable. However, if there was no possibility of exploiting platy limestone in a particular site, the limestone can be exploited everywhere, providing the geological characteristics are the same. From the geological research within the project, it has been shown that platy limestone in Italy and Slovenia came from the same geological units, as well as the entire stratigraphic sequence. Otherwise, in Croatia and Bosnia and Herzegovina the geological units are different, in terms of age, fossil content and lithological characteristics.

For these reasons, in the first instance, it is recommended to re-use platy limestone or recycle platy limestone plates from old abandoned dilapidated houses, abandoned materials or inactive quarries.

After closing, regardless of the technology and production program, each quarry will represent a specific wound in the natural environment.

We want to promote the continuation of the use of platy limestone together with natural heritage protection, by preserving and promoting the typical karst cultural landscape.

In the frame of the RoofOfRock project, the limestone quarries in all the 4 countries of the eligible area have been inventoried and surveyed. A field form has been specially designed for field activities in order to characterize all the quarries where platy limestone layers have been observed from a lithological, geomorphological, paleontological and legislative point of view. The possible conflicts with legislation in force have been verified. According to the obtained results and considering different scenarios of

the conflicts between exploitation and preservation, 9 quarries/delves for the sustainable exploitation of small quantities of platy limestone have been identified and are described below.

ITALY

The occurrence of platy limestone is extremely limited in the Italian part of project area. In the frame of the RoofOfRock project, 24 quarries with limited horizons of platy limestone have been observed; among them, 16 are in areas that are somehow protected or have some limitations. The remaining quarries do not exhibit adequate quantities of material for exploiting.

However, small quantities of thin limestone slabs are widespread over the Italian part of the Carso/Kras, and are gathered as waste materials in many quarries.

In the case of the restoration of a typical karst house (or church) or the building of a new one, if there is no possibility of re-using old plates or opening a new quarry or exploiting an abandoned one, it is advised to resort to the nearby Slovenia.

One of the outputs of the project is the geological characterization and mapping of the platy limestone units in all the Adriatic Karst Region: in this framework, the geologists highlighted that the platy limestone horizons in Slovenia and Italy belong to the same geological formation and are practically identical. This is the reason why, in case of need, it is suggested to create a common market and the sustainable small economic exchange of limited quantities of platy limestone between Slovenia and Italy.

SLOVENIA

After careful consideration of the situation in the field and an assessment of the quality of the platy limestone slabs, two areas for limited exploitation with a need for a synchronous paleontological monitoring have been recognized:

- the surrounding area of Komen - microlocation Gabrovica;
- hill Mrtvaški hrib – along the local road between Komen and Škrbina.

In all other locations, there are relatively small outcrops of platy limestone on the surface or near the surface or the platy limestone materials are characterized by a poor quality. Given the predominantly horizontal or sub-horizontal bedding, a re-acquisition of platy limestone in large areas should be opened. However, from an environmental standpoint this is virtually impossible in the Carso/Kras area, since almost the whole of the Kras is under Natura 2000 protection and special permits are required. Even in above-proposed sites it is not possible to excavate large quantities of high-quality platy limestone slabs.

CROATIA

For larger quantities of platy limestone, the following possible sites for extraction have been identified:

- Bale (Istra),
- Benkovac (between Smilčići village and Mejanica hill, Zadar County),
- Vestac and Podgažul (Island of Brač, Split County),
- Koludrovi doci, Kupište and between Grohote and Necujam (Šolta Island, Split County),
- Lovište and Donja Nakovana (western side of the Pelješac peninsula, Dubrovnik County),
- Vela Luka and Žrnovo (Korčula Island, Dubrovnik County).

WESTERN HERZEGOVINA

After careful consideration of the situation in the field and an assessment of the quality of platy limestone slabs and the absence of natural heritage obligations, the following sites are suitable for the exploitation of platy limestone: the Podveležje site (east of the city of Mostar and Dobroč village), the Dretelj-Zvirovići site (northwest of Čapljina), the Drinovci site (south of Grude), the area around the Raška Gora and Vrđi sites (north of Mostar), the Polog (Žovnica) site (west of Mostar) and the Borićevac site (northeast of Posušje). Among these, the most representative is:

- Dretelj-Zvirovići (northwest from Čapljina)

4. WHAT TO DO IN CASE OF FOSSIL FINDS

Fossils (from Latin *fossilis*, obtained by digging) represent the remains of animals, plants and other organisms from the remote past. They vary in size from microscopic, a few micrometres in diameter, to gigantic, such as dinosaurs and trees, which can be many meters long and weighing many tons. Within the RoofOfRock project we considered fossils, which are recognized to be significant in the scientific context, such as fish, plants, dinosaurs, etc.

Before starting any major ground works involving shafting in the territory of platy limestone (exploitation of major land reclamations, etc.), the competent institutions should be notified and, if necessary, they would organize the paleontological monitoring and storage of excavated limestone slabs for the reconstruction of authentic local architecture.

The general rule in the case of finding a fossil is that the person who found the fossil has to notify the competent organization about the discovery. The stated rule is common for all four countries. The competent organization in Slovenia is the [Institute of the Republic of Slovenia for Nature Conservation](#) (an institute under the Ministry of the Environment and Spatial Planning), in Bosnia and Herzegovina the competent organization is the [Ministry of Environment and Tourism](#), in Italy is the [Ministry of Cultural Heritage and Activities and Tourism](#) and in Croatia is the [Ministry of the Environmental and Nature Protection](#).

Slovenian law also prescribes rules on how to react in the case of finding a fossil while an activity is being carried out. In that case, it is necessary to

stop the activities, protect the fossil finds and immediately notify the organization competent for protecting nature ([the Institute of the Republic of Slovenia for Nature Conservation](#)). Within seven days of being notified, the Institute must issue protection guidelines. After the Institute confirms that safety measures have been taken, the activities can continue. The same rule is prescribed in the case of finding a fossil that has the status of valuable natural feature.

Italian legislation is similar to the Slovenian. The only difference is that in Slovenia fossils could have a status of a “valuable natural feature” while in Italy they have the status of “landscape assets” and “public unavailable heritage”. The “public unavailable heritage” is inalienable and cannot be subjected to private rights except in the manner prescribed by law. Collecting minerals and fossils is absolutely prohibited, except with permission granted for scientific purposes.

In Croatia, minerals or fossils that are significant because of their rareness, size, appearance, or educational and scientific significance must be reported to the Ministry within eight days. They are protected on site (in situ) if possible or, if not, ex situ.

In Western Herzegovina, for consideration of potential impacts on the extraction of platy limestone and issues related to fossils, a fundamental document is the [Environmental Strategy of the Federation of Bosnia and Herzegovina 2008-2018](#). Many natural heritage sites are protected by several laws and legal acts (look at the matrixes at the beginning of the document).

From the legislative point of view, in Italy there is no distinction between high value fossils, such as vertebrates (e.g. fishes) and low value fossils, such as microfossils, etc. Conversely, in Slovenia and Croatia laws distinguish the type and value of fossils. For this reason, the qualitative assessment of the importance of the paleontological content of platy limestone is crucial.

In order to preserve paleontological heritage, the presence of a palaeontologist and/or geologist is crucial during exploitation activities, since they can assist quarry operators to recognize and evaluate the importance of a fossil outcrop.

In the future, platy limestone exploitation and natural heritage preservation should integrate common legislation and common good practices, therefore materials similar to platy limestone should imply similar laws of natural protection and sustainable exploitation.

5. PLATY LIMESTONE AND GUIDELINES IN ARCHITECTURAL CULTURAL HERITAGE

5.1. STONE BUILDINGS

When performing renovation, reconstruction or maintenance work, it is necessary to pay attention to the coordination between the protection criteria as this is the only way to transfer the unique authentic expression of heritage to future generations. We must preserve the original architectural heritage in its unique form to the greatest extent possible, which means the preservation or professional objective interpretation based on the principles of architectural heritage conservation.

The replacement of the original material in each renovation is a difficult task. The replacement of a stone roof with red tiles changes the appearance of the building and affects the building's height. Red tiles require an inclination of only 30°. Such an inclination, coupled with the retention of the drip edge, lowers the height of the ridge, which is noticeable on some side façades where the line of the previous stone roof has been retained.

In his survey of the Karst, Božidar Premrl uses the term **grey and white limestone**, which are not used in architectural and geological terminology. The RoofOfRock project has achieved a qualitative milestone in this respect as the experts from various fields have revamped the terminology, suggesting the following:

- **laminated dark limestones (*grey*)** are bedded in thin horizontal layers; e.g.: Komen limestone that emanates a distinct sharp

smell when slabs are being extracted. Laminated dark limestones are less durable, they flake in layers and become weathered more quickly.

- **white** limestone occurs at tectonic fractures on the Karst, the plates are vertical to the sediment and of various thicknesses and fractures. Marine animal fossils are common in these plates, e.g.: in the Lipica quarry.

5.2. ARCHITECTURAL ELEMENTS

The roof represents the fifth façade of the building and is part of the locality's image, which is especially true today when aerial photography is widespread. Roof surfaces are part of the image or identity of a settlement. The structure's verticals (walls) and horizontals (floor divisions) are protected by the roof from permanent moisture, the washing out of binding materials by dripping water, leakage, moisture penetrating wooden structures, the corrosion of metallic load-bearing elements, etc. A building without a roof will decay quickly and there will be damage to all elements of the building, which are then difficult to repair.

Roof reconstructions are commonplace in practice with a common method being the simultaneous restoration of the roofing material and the roof support structure (roof frame). Because slate roofs have only rarely been preserved or can only be found in archive sources or oral accounts, building reconstructions are rare.

The preservation of a building's height also entails the preservation of the roof. Roofs covered with quarried limestone plates have a steep pitch, generally 45° but in some cases as much as 65°. The steep pitch of the roof offers rapid and efficient drainage of rainwater. Structures with a pitch of 45° have an advantage over other roofs on account of the simplicity of putting together the roof frame. Component parts are connected at right angles, which reduces the possibility of errors.

When roofs were renovated in the past, extensive technical mistakes were made that are now causing problems with the functioning of buildings. The use of reinforced concrete roof bands is a reasonable solution for strengthening a structural roof from the local point of view. Difficulties arise on account of the significant increase in the building's weight at the roof level,

with the walls beneath being insufficiently reinforced, which results in the lower part of the building being too soft in the event of an earthquake despite the upper portion of the building being structurally sound.

5.2.1. ROOFS

In order to calculate the amount of stone required for the roof, we use quantities per square metre (m^2) and cubic metre (m^3). When renovating an existing roof, it is necessary to replace part of the weathered and missing roofing tiles (up to as much as 80%). Overlap must be taken into account when calculating quantities; overlap can be either standard or increased. The increased type of overlap is frequent on roofs of residential buildings, while standard overlap is found on commercial buildings and less demanding single-cell buildings (shepherd's huts, chicken coops and pigsties). Buildings outside built-up areas (in forests, at the edges of pastures and fields) that are intended for occasional use and have no commercial significance employ the standard overlap roofing method.

We should mention the special features that we encounter regularly when surveying heritage: elements can either be uniform in their general features or specific from one building to another. All of the abovementioned structures and elements were created based on the available sources of stone and using the available financial resources, as well as by employing the knowledge of masters who handled the building material. The mentioned plate thicknesses, the top view dimensions of plates and other specification are general and frequent; however, exceptions and special features must be considered as well. The specific weight of the hollowed out or heavily porous Karst limestone ranges from 2640 to 2692 kg/m^3 . When using roofing stone plates (tiles) on the roof and other architectural elements, we use the weight of stones without pores or hollows, which is 2720 to 2791 kg/m^3 . The data on the weight of the roofing material affects the roof's load-bearing structure. The calculation of the weight and volume of the elements is a compulsory task when inventorying architectural heritage. When preparing the detailed design for the renovation, reconstruction or new construction, the project design engineer produces a detailed project design inventory of the works and quantities along with a cost estimate. Without such an expert's report, the planning is incomplete and the management of the buildings representing architectural heritage is unsuitable. When estimating the weight of the roof, the following must be added to the weight of the roofing tiles: the weight of mortar, of the

sub-structures on which tiles are placed, of spacing rafters (in the case of a ventilated roof), of secondary roofing material (may be disregarded), of the sarking boards between rafters, of heat insulation (in the case of an insulated roof), of the load-bearing roof structure, of the lower insulation layer (the enclosing of insulation differs depending on the material) and of the final finishing layer of plaster or other finishing of the visible surface of the roof frame.

The list comprises the typical layers of the roof frame cross-section. Variants (structural thicknesses, selection of materials) differ from one project to the next. The planning of roofs and changes to the building's load-bearing structure without suitable project design documentation and the acquisition of a building permit is prohibited. Project designs are prepared by certified architects in accordance with the conditions and approvals of expert services and in cooperation with other experts and engineers involved in the building project design processes.

ROOF TYPOLOGY DETERMINATION

The calculation of the surface area of the required quantities of stone for the roof is performed in two steps. Necessary documentation is prepared first, which is followed by the data for the calculation.

In terms of the cross-section, the roofing material is laid in several layers, i.e. up to four layers in the vertical profile of the roof cross-section. A stone-built roof is heavy. The documentation comprises several types of content, but we focus on the measurements and plans at this point as they suffice for the calculation of quantities. Quality documentation allows the sound planning of all subsequent project phases. Economic use of resources is not of major concern at this point as the documentation serves as the basis for subsequent decisions on the comprehensive protection and management of the building's heritage (immovable and movable). At this point, we only list certain basic methods of production of a working schematic of the building's height:

- a. measurement and top view printouts of the building's heights (external wall dimensions);
- b. printout of a cross-section in the transverse direction of the roof with the eave (soffit) indicated along the drip edge. This cross-section clarifies other key characteristics of the building (pitch of the

roof, plate laying method, construction of the roof frame, determination of the roof thickness);

- c. the printout of the cross-section in the longitudinal direction of the building with the gable indicated.

We design the data table, enter the quantities in metres and use trigonometric functions or Pythagoras's theorem to calculate the surface areas or measure the lengths from the drawing. Data is determined either by calculation or graphically as both methods are possible.

The measurement of lengths from the plans is straightforward, but the documentation used must be of quality and authentic. The usefulness of plans is demonstrated in cases where the roofing is a combination of two types of roofing materials (the use of stone exclusively in the gable walls, the roof of the building, the eaves (soffits) or when covering parts of buildings that project beyond the basic body of the building). If no plans are available for the building, Pythagoras's theorem is used to calculate the lengths of the roof in cross-section. Using trigonometric functions, we calculate the pitch values for the roof. The calculation procedure is as follows:

- a. determination of the type of overlap: increased/standard;
- b. entry of the length and width of the roof into the floor plan;
- c. entry of the rectangular distance from the drip edge to the top of the ridge;
- d. measurement of the roof pitch from the plan;
- e. measurement of the length of the roof from the ridge to the drip edge;
- f. in case of a combination of stone roofing tiles and a different roofing material, measurements of the dimensions of each roofing type separately;

A. SIMPLE SHED-TYPE ROOF

Roofs are simplest on smaller, simple buildings. Buildings that are of modest, straightforward rectangular shapes. Rafters are placed on the outer load-bearing walls, onto which the stone roof is then placed. The

roofing plates undergo minimum processing. Plates have larger visible upper surfaces (standard overlap type). Surface areas are between 12 and 15 cm. Shed-type roofs are also common in the construction of simple, architecturally less important annexes to main buildings.

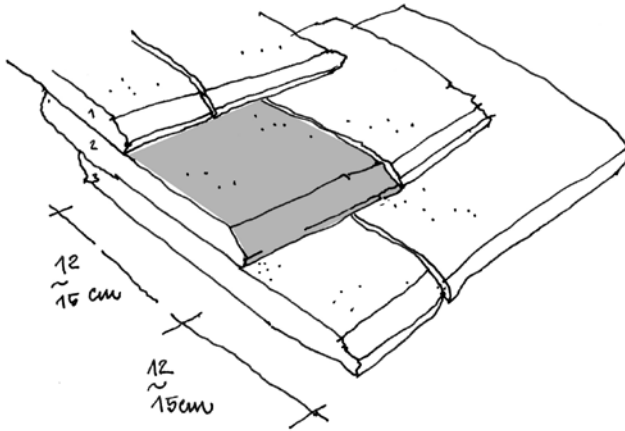

Figure 6.
Schematic of the overlap
on a shed-type roof
covering simple buildings

B. GABLE ROOF

The most frequent roof type is the gable roof. Owing to the sheer weight of a stone roof, gable roofs are generally symmetrical. The symmetry of both sides of the roof allows equilibrium and equal loads on the roof support structure from all sides.

The weight of stone roofing plates can be as much as 500 kg/m^2 . The covering of a gable roof is performed simultaneously on both sides of the roof. When covering roofs, one can observe the arrangement of plate sizes depending on the position on the roof. The selection of roofing plates depends on the following:

- along the drip edge, stone plates are larger as they are more exposed (weather, the weight of the plates above);
- along the ridge (upper edge of the roof), plates are smaller as an increase in weight in the ridge area only hinders the execution of the work and can have negative effects during an earthquake (greater forces during earthquake accelerations);

- the visual structure of the field of the roof towards the ridge is layered into thinner lines.

The described method of construction is termed *tectonics* in architecture. The simultaneous symmetry of covering with stone plates indicates tectonics. The size of the plates towards the top decreases, and the plates are also thinner towards the top.

C. MULTI-SIDED ROOF

Roofing stone plates are semi-carved plates and are processed as little as possible, i.e. only as much as necessary to fit the roof and to reasonably drain precipitation. Stone plates can be used to cover various floor plan shapes including rectangular, square, multi-angled and round designs.

Multi-angled shapes are generally symmetrical and rest on gables or the side walls of the building. The most frequent floor plan shapes in the area of the Karst and the Adriatic are octagonal houses or derivations thereof with sections of the basic floor plans. These floor plan designs are frequent for sacral buildings (apses, front door canopies) as well as for annexes to residential buildings (e.g. *spahnjenca* black kitchens on the Karst, Bišćević houses in Mostar).

Figure 7.
Annex to a house in Mostar supported on columns. The floor plan of the annex is rectangular and the roof has three sides. Bišćević house.

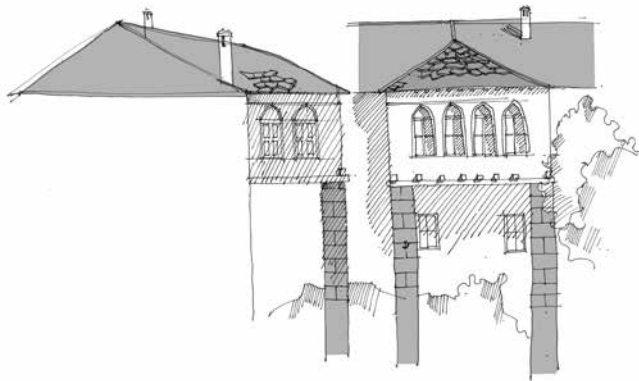

5.2.2. ROOF FRAMES OF STONE-BUILT ROOFS

The roof structure supports the roofing tiles and forms part of the building's structure. The wooden roof structure is the most frequently employed. It is constructed in several ways; frequently as a triangular wood construction (rafter and collar tie). The crucial role is played by well-made wooden connections between structural elements. The quality planning and execution of wooden roof frames with wooden connections that are characteristic of the local environment are of the utmost importance. New wooden roof frame designs are also possible (glued laminated beams, trusses).

The doctrine of renovating stone buildings using reinforced concrete angled slabs with reinforced concrete bond beams was quite frequent decades ago. A reinforced concrete shell is earthquake resistant, but is unsuitable during an earthquake when combined with stone walls. Examples of the roof structure slipping off the building are frequent. The building is damaged severely by such slippage. When renovating, reconstructing or building new buildings with a stone roof, it is better to employ wooden roof support structures. A wooden roof frame is more dynamic during an earthquake and does not exacerbate the swaying of the building during earthquake accelerations. It should be mentioned that changes to the construction of the building are only possible on the basis of a comprehensive project design and the acquisition of a building permit.

5.2.3. PLATY LIMESTONES AND ROOF COVERING METHODS

In general, we distinguish between two methods of covering roofs – increased and standard overlap.

The laying of roofs with increased overlap has a vertical thickness of 10 to 25 cm, while the standard overlap yields a vertical thickness of 7 to 10 cm. Thicknesses can differ from the stated because stones undergo minimal processing and are not of a constant thickness, width or length. Roofing stones along the eaves are 6 to 8 cm thick and roughly 50 × 70 cm in size. Along the drip edge, double plates (double headlaps) are installed and allow the suitable drainage of precipitation. Dimensions are indicative as they are determined by the availability of material.

In Herzegovina and partly also in Dalmatia, there are roofs where stone plates are laid on roofs in two ways: the edges of the roofing are laid in the direction of the building's edges, while the internal fields of the roof have roofing stones laid at an angle. The angle is generally 45°. Such an execution of the roof surface allows the point drainage of precipitation. Stones can have less processing done to them, i.e. without the finishing of the plate ends. Roofing stones are up to 9 cm thick and roughly 50 × 70 cm in size. Roofs employ multiple headlaps.

A stone roof can be constructed without an additional roof frame. The roof is thus uniform in terms of materials. The corbelling technique is used for simple buildings such as shepherd's huts, which are common in the Adriatic area and in the Karst hinterland.

One reasonable question to ask concerning the above variants is the insulation. There are two types of heat insulation. In the case of stone-built buildings or buildings with exposed structural elements on the façade, the installation of heat insulation on the exterior side of the walls is an unsuitable architectural solution. Structural elements on the façade determine the architectural expression of the building from the point of view of typology or function, dating of the building and the material processing method. In such cases, heat insulation is installed on the interior side of the walls. The installation of interior heat insulation requires technical adaptations, changes to the architecture of the internal spaces and a partial reduction of areas/volumes of the spaces. Such procedures are often associated with the restoration of the load-bearing structure, the optimisation of installations and the assurance of suitable fire safety. When installing new installation in the building, we do not recommend making holes or channels in the stone walls to accommodate the installations. Such destructive procedures weaken the wall and the structure. We recommend that the ducting for the installation be installed on the outside surfaces (on the surfaces of walls) and then covered with suitable heat insulation.

In cases of simple buildings without structural elements in the façade, external insulation of a suitable thickness can be installed. Owing to the thickening of the building shell, individual elements must be moved to a new position in order to be in the same plane as the façade. Such construction is technically demanding as it is difficult to avoid thermal bridges. The relocation of elements (sills, massive window frames) from walls to new positions weakens the stone structure itself. They are therefore more of an exception and not recommended.

These interventions on older buildings must ensure suitable energy consumption. Moisture is a frequent problem in older buildings as it penetrates from the outside (backfilled parts) and from the foundations. Years of moisture in the structure changes the properties of the materials. The building must be dry prior to installing heat insulation. The building must have suitable hydro insulation and comprehensive ventilation. Architects and expert services from various fields must therefore determine suitable solutions for these problems. Mere compliance with the laws and guidelines in the area of energy efficiency only represents one aspect of designing a suitable living environment for a modern standard of living.

ROOF ELEMENTS

In addition to stone-covered and completely stone roofs, there are many more different architectural elements in the area where platy limestone is found. These elements are often of secondary importance, but have a higher aesthetic value. When studying these elements, we have discovered their true value on countless occasions and we link them to their function on the building.

Water drainage from the roof is not left to chance. The area of the Adriatic and its hinterland has dry summers and precipitation-abundant months during the cold part of the year. Fresh water is less frequent here than elsewhere, which makes it a valuable commodity. Rainwater is often channelled from roof gutters into underground rainwater tanks.

Roof openings on stone roofs are limited to the layers of roofing stone plates. They are intended for attic ventilation. Larger openings are made using dormers.

5.2.4. OTHER ARCHITECTURAL ELEMENTS

BUILDING PERIMETER

The walls or shell of a building feature several different elements. The most prominent elements are doors, windows, niches for statues, stone sills, shade slabs, corner stones, pressure-relief stone arches and other elements in the form of cantilevers and pilasters.

Openings in the building shell play several roles and serve several purposes. They are frequently located on the axis as this better distributes the weight of the elements in the wall. From the point of view of façade design, this arrangement is reasonable because it introduced a rhythm of openings in the horizontal and vertical directions. The appearance of the façade is enhanced by shadows created by the elements that lie on the façade plain. In stone architecture, openings are framed by rough-carved stone frames (*jerta*). A pressure-relief stone arch is built above the opening and serves to relieve the pressure on the lintel.

Figure 8. Loading and the reason for the distribution of openings along the axis of the building shell. A small pressure-relief arch above a stone lintel distributes the vertical load to the edges of the opening.

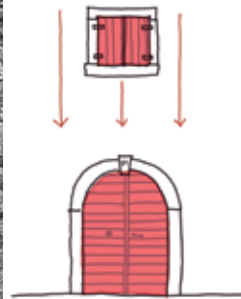

FIREPLACE AND SMOKE EXTRACTION

The chimney and fireplace are especially expressive architectural elements. The chimney is a vertical shaft for smoke extraction, and the external parts of the chimney serve more than just aesthetic purposes. The cross-section of the chimney demonstrates the functionality of the built in stone plates.

When the chimney is built partly into the wall and partly outside the plane of the wall, it is supported by stones in the cantilever and arch. The chimney becomes narrower towards the top as this effectively reduces the weight of the element towards the top. Where the circumference changes, crossbars are constructed that highlight the division of the element.

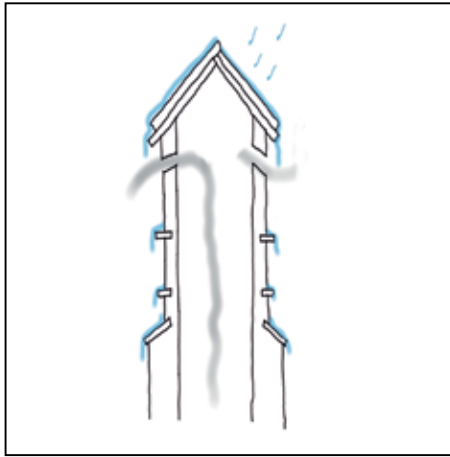

Figure 9.
Chimney rim division
function – drainage of
precipitation and good
ventilation.

5.2.5. PAVING

Stone veneer is also used for paving. Paving stone plates are laid on a sand bed in vernacular architecture. This detail has been preserved to this day and has only been complemented by cement (dry concrete bed).

The role of paving is a multi-faceted one. The aim of strengthening a surface is complemented by the role of paving and its position in the urban fabric. A city or village square is always surrounded by important buildings (cathedral, town hall, court house, city granary), which is why the design of market surfaces follows the surrounding architecture. A square in the city is generally carefully thought out and uses regularly cut and shaped plates. Less means are devoted to a square in a rural environment, where rough carved plates are used.

The paving in public areas must ensure serviceability for different users (pedestrians, vehicles and events) and allow use in different seasons. Street paving has a clear focus on larger stones with strong edges. Diagonal paving facilitates adaptation to undulating surfaces and changes in street directions. We can see an example of this paving in Zadar, Croatia. Stone paving is more of an exception than the rule around shepherd's huts in the rural environment. Stones are not shaped in any way and are placed close to one another.

Figure 10.
New stone paving made of
platy limestone.
Elements are cut into
regular shapes, grouts are
open with grass growing
in them. The square
provides for good drainage
of rainwater. With its
clear modular orthogonal
network and different
sizes of stone, it creates
a dynamic surface in the
inner courtyard. Divača,
Slovenia.



Platy limestone is a non-standard building material in architecture. The team of experts who participated in the RoofOfRock project finds that there is only a handful of quarries in the entire project area that could provide suitable platy limestone. The only possibility for using this building material is the recycling of stone plates from existing buildings. The re-use of such building material represents an additional workload – verification of the suitability for re-use in a new location or new building. We should emphasise that such material has already been exposed to the external effects of the weather and is past the optimum time for the use of the material. These stone plates are predominantly (more than 50%) of lower quality or even unsuitable for re-use in architecture. The quality is not the only thing making them unsuitable since re-use must also consider the local origin of the material. Stone from Dalmatia, for example, cannot be re-used in Istria and the other way around, even if it is a similar shape on the original building and the replacement building.

Upon the decision to re-use limestone plates, the responsible project manager or head of conservation interventions must obtain technical approval that confirms the compliance of the re-use of material.

The design of the structural elements and buildings made of stone does not only mean buildings with stone blocks and laying of plates onto the roof structure. The design of dwellings, work premises, sacral buildings,

fortifications and other small structures is extremely diverse in the entire project area. The uniformity of the building material and the variety of shapes bear witness to the rich cultural heritage of the communities included in the project.

6. RECOMMENDATIONS FOR COMMON LEGISLATION

The fact that in Karst areas, where traditional construction has used stone as the basic material for centuries (e.g. stone for roofs, portals, paving, etc.), the primary autochthonous material – platy limestone – is being replaced with imported and/or even a completely different type stone or material (e.g. sheet metal roofs) is entirely unacceptable. The reason for these actions on the part of investors and construction companies is a simple one: in a larger part of the project area, with the exception of Croatia, there are no quarries where one can – legally and based on mining rights – exploit and extract platy limestone that has been traditionally used as a building material in Karst architecture in the past.

There has been a desire on the part of the project team and the broader public for expert groundwork and recommendations to be prepared for the potential future amendment of legislation in a way that would allow the legal acquisition of suitable building material, i.e. platy limestone, which would be used especially for the renovation of cultural heritage buildings. The fact is that it is impossible to ask building owners and future investors to use autochthonous building material for the conservation (restoration) or renovation of buildings, which may even be protected as cultural monuments of local or national importance, if that material cannot be obtained legally.

The question that arose when drafting the guidelines for legislative amendments is whether the extraction of platy limestone could be regulated within the scope of nature protection legislation. The case in question involves the extraction of small quantities of platy limestone for a

particular purpose, i.e. the renovation, conservation or restoration of cultural heritage buildings.

As regards nature protection legislation, it should be mentioned that its main aim is to protect nature or contribute to nature preservation through legislative measures. Legal acts employ prescribed measures to protect valuable natural features, protected areas, Natura 2000 sites, ecologically important areas and protected mineral and fossil sites. As has been found within the scope of a comparative legal analysis of the valid nature protection legislation in Slovenia, Bosnia and Herzegovina, Croatia and Italy, platy limestone has none of the prescribed statuses, which is why nature protection legislation does not prescribe direct restrictions or prohibitions. According to the regulations in force, its extraction can be limited or even prohibited if it is located in an area under a special protection regime as the nature protection legislation in force may limit or prohibit, for example, interventions in nature, the commercial exploitation of natural resources, the excavation or removal of rock, minerals or fossils, even the exploration and removal of the research material from nature as well as visiting or viewing a particular area. The prescribed restrictions represent an obstacle to the extraction of platy limestone, and we should emphasise in this regard that the law prescribes restrictions or prohibitions on general measures, while detailed rules of conduct in an individual protected area are stipulated by the acts issued by the state or the local community.

Since platy limestone, like all natural stone, is classified as a mineral resource, the legal basis for its extraction is the mining legislation. Despite the above, nature protection legislation prevents the extraction of platy limestone in certain locations for various reasons, which it does through prescribed protection measures.

The Slovenian [Nature Conservation Act](#) allows the limitation or prohibition of certain activities in areas with valuable natural features, protected areas, Natura 2000 sites and ecologically important areas, which can represent an obstacle to the extraction of platy limestone. In areas with valuable natural features, the act prescribes the option of restrictions on activities or the use of a valuable natural feature, but only to the extent that is urgent for the preservation of the valuable natural feature, its protection or renovation. Activity or use of the valuable natural feature are limited by an act on protection or an act on temporary protection. If the restriction of the activity or use of the valuable natural feature is not prescribed by way of the act, the area with the valuable natural feature and

its protection regime does not represent an obstacle to the extraction of platy limestone.

Slovenian legislation prescribes certain restrictions or prohibitions in protected areas differently or in greater detail. The general rule is that interventions and activities in protected areas are to be carried out in accordance with the act on protection and the management plan, whereby the management plan should determine the protection regime, development orientations and other content stipulated in the act on protection in detail. Slovenian legislation differentiates between narrower and broader protected areas. In broader protected areas, the act prescribes the possibility of the act on protection limiting or prohibiting the following interventions or activities:

- interventions and activities that affect the physical environment and threaten the original state of nature – the extraction of platy limestone in small quantities generally does not threaten the original state of nature;
- the construction of new buildings – the reconstruction of a building or structure does not represent a new construction, which is why amendment of the legislation is not required;
- the commercial use of natural resources, with the exception of construction in protected areas – in cases when the commercial use of natural resources is prohibited by the act on protection, this represents an obstacle to the extraction of platy limestone. The law does provide one exception, i.e. in the case of construction in a protected area, meaning that the exception does not apply to construction outside the protected area. Legislation should be amended in this part by making the exception apply to the extraction of natural resources in small quantities or for a particular purpose, e.g. conservation, restoration or renovation;
- all other activities that could represent a significant threat to the protected area – the extraction of platy limestone in small quantities generally does not represent a significant threat to the protected area, which depends particularly on the characteristics of the protected area;

whereby the characteristics of the protected area and the purpose of protection need to be taken into account in all cases when issuing prohibi-

tions or restrictions. The essential aspect is that it is impossible to prohibit or restrict the renovation of buildings by way of the act on protection pursuant to the existing legislation; this can only be done for the construction of new buildings. As regards the narrow protection areas, the act prescribes the rules of conduct for an individual type of the narrow protected area. The law thus prescribes a general rule for a natural monument area, i.e. that it is prohibited in the protected area to perform interventions in nature in a way that could cause a deterioration of the state of a valuable natural feature, change, damage or destroy a valuable natural feature, and modify the conditions or the state by modifying, damaging or destroying a valuable natural feature or impairing its aesthetic importance. The act on protection can specifically prohibit or restrict:

- the performance of interventions that affect the physical environment – proposal for the following wording to be added: *“that threaten the original state of nature”* as this limits the possibilities for prohibitions and restrictions;
- causing vibrations and explosions – in the case of a prohibition on causing vibrations and explosions, the said prohibition represents an obstacle to the extraction of platy limestone (unless there is a different way of extracting platy limestone that does not cause vibration or requires explosions), while in the case of restrictions, detailed rules are prescribed by way of the act on protection that can stipulate time restrictions on when eventual restrictions can apply (on a daily or annual level);
- commercial exploitation of natural resources – if the commercial exploitation of natural resources is prohibited in accordance with the act on protection, such a prohibition represents an obstacle to the extraction of platy limestone. The Nature Conservation Act does not prescribe any exceptions in this part, which is why we propose that the following wording be added: *“with the exception of the commercial exploitation of natural resources in small quantities”*, while the quantity of the extracted natural resource could be limited by way of the act on protection;

whereby it is prohibited in the protected area to carry out activities using means and in a manner that could cause significant changes to the biodiversity, structure and function of ecosystems, and to perform activities at times when the existence of flora and fauna is threatened, while the act on protection can serve to prohibit or restrict:

- the performance of interventions that affect the physical environment – proposal for the following wording to be added: “*that threaten the original state of nature*” as this limits the possibilities for prohibitions and restrictions;
- causing vibrations and explosions – in the case of a prohibition on causing noise, vibrations and explosions, the said prohibition represents an obstacle to the extraction of platy limestone (unless there is a different way of extracting platy limestone that does not cause vibrations or noise or requires explosions), while in the case of restrictions, detailed rules are prescribed by way of the act on protection that can stipulate time restrictions for when eventual restrictions can apply (on a daily or annual level);
- all other activities that could represent a significant threat to the protected area – this is a general rule that aims to safeguard the protected area so that its essential part is not threatened. Because the extraction of platy limestone in small quantities cannot significantly threaten the protected area in the majority of cases, we believe that a legislative amendment is not required in this part;

whereby the characteristics of the protected area and the purpose of protection need to be taken into account. This is an arrangement similar to the case of a natural monument with the difference being that the act on the protection of a natural reserve allows a restriction or prohibition on causing noise. The law thus prescribes a general rule for the area of an integral natural reserve, i.e. that it is prohibited in the protected area to perform interventions or perform activities that threaten the preservation of the protected area, the deliberate destruction of flora and fauna and the presence of people, however, with the exception of those carrying out supervision, while detailed rules can be laid down in the act on protection. Despite the prescribed rule, the extraction of platy limestone in the area of an integral natural reserve, i.e. in small quantities, is possible, which is why a legislative amendment or supplementation is not reasonable in this part.

The rules on conduct in Natura 2000 sites are prescribed in greater detail in the [Natura 2000 site management programme](#). The case under consideration involves sites that are protected in accordance with the European legislation, which is why the eventual amendment of the legislation is unreasonable as European law must be observed. In order to perform interventions in Natura 2000 sites, an [environmental impact assessment](#)

must be performed in accordance with the legislation, within the scope of which the competent authority must determine whether the extraction of platy limestone in small quantities could have a negative impact on the environment or a Natura 2000 site, which it would not on account of the small quantities extracted. In accordance with the legislation, the extraction of platy limestone is possible in ecologically important areas, as are all interventions and activities with the legislation only requiring the performance of interventions or activities to be planned to preserve the natural occurrence of habitat types and the habitats of plant and animal species, their quality and the connection between the habitats of populations to the greatest extent possible, as well as to enable re-connection if such were discontinued by the planned intervention or activity.

Like Slovenian legislation, the Croatian nature protection legislation prescribes a set of prohibitions or restrictions for protected areas; however, in a more general sense:

- integral reserve – the prohibition of commercial and other activities, while visits, research and monitoring of the state of nature are allowed – the question arises whether exceptions should be provided for in this area;
- national park – in addition to the prescribed prohibition of the commercial exploitation of natural resources, there is a general rule that only interventions or activities that do not threaten nature are allowed – the proposal is for an exception to be granted, i.e. “*with the exception of the extraction of natural resources in small quantities*”, or for the purpose of further use to be added, i.e. “*with the exception of the extraction of natural resources for the purpose of building reconstruction*”;
- special reserve – interventions or activities that contribute to the conservation and improvement of the properties of a protected area are allowed, while all interventions or activities that degrade the state of the protected area are prohibited – in the case under consideration, it is not necessary to provide an exception as the prohibition is limited to the endangerment of the essential properties of individual areas;
- the rule that interventions or activities are allowed only if they do not threaten the essential properties of an area applies to areas of natural parks, regional parks, natural monuments, important land-

scapes, forest parks and the so-called park architecture monuments – in the case under consideration, it is not necessary to provide an exception since the prohibition is limited to the endangerment of the essential properties of individual areas.

It is also important to mention that the Croatian [Spatial Planning Act](#) defines the protected coastal area, i.e. a belt of land and islands with a width of 1000 metres from the coastline. In this area, which is of special interest to the state, exploitation and surveying of mineral resources, which includes platy limestone, are prohibited. Despite this, the second paragraph of Article 48 of the abovementioned act expressly permits the exploitation of architectural-construction stone for the purpose of continued traditional activities on the islands of Brač and Korčula and the Pelješac peninsula, whereby this is permitted under the conditions stipulated by the Croatia [Mining Act](#) – exclusively based on a concession.

Like the Croatian legislation, Bosnian [nature protection legislation](#) does not prescribe a detailed set of prohibitions or restrictions on interventions or activities, but rather just a general rule that only interventions or activities that do not damage a protected area or do not impair the properties that lead to an area being protected are allowed in protected areas and other protected valuable natural features. In view of the above, we can conclude that an amendment to Bosnian legislation is not urgently required as the extraction of platy limestone in small quantities cannot cause a deterioration of properties that lead to an area being protected, while an arrangement for exceptions could be proposed for the Croatian legislation as evident from the preceding paragraph. A more general arrangement is contained in Italian legislation as areas with valuable natural features that are protected by law prohibit their owners or holders from destroying them or from making any changes that impair the state of the valuable natural feature. Italian legislation prescribes no further restrictions or prohibitions in regard to valuable natural features. The same prohibitions or restrictions apply to protected areas as well. It can be concluded from the above that the general prohibitions or restrictions prescribed by the legislation in force do not represent an obstacle to the extraction of platy limestone in small quantities.

The preservation of authenticity and originality in a particular milieu characterised by the use of platy limestone in building construction is regulated by the [European Landscape Convention](#). The convention was

adopted by all four countries participating in the RoofOfRock project to achieve greater uniformity in the protection and realisation of the ideals and principles that represent their common heritage and for the objective to be achieved mainly through agreements in economic and social areas.

The cultural landscape contributes to the formation of local cultures and is the fundamental element of European natural and cultural heritage. It also contributes to prosperity and the strengthening of Europe's recognition. An important element of the cultural landscape in participating countries includes platy limestone as the characteristic building material that is present in local construction and thus forms a part of the common identity of all countries.

Over the course of the project, all aspects and characteristics of the Karst cultural landscape related to platy limestone have been identified, i.e. from its extraction (sites, extraction method, specific geological features, etc.) to its use that is demonstrated in today's cultural heritage.

It would therefore be necessary to allow the use of locally available material, maintenance and replacement with the same material for the preservation of immovable cultural heritage in accordance with the provisions of the [European Landscape Convention](#), as well as other international guidelines and conventions ([Nara Document on Authenticity](#), UNESCO conventions and guidelines, etc.). Only in this way can the local identity be preserved, e.g. construction that has been characteristic of individual areas for centuries. By allowing the extraction of local materials in an area, all aspects of this characteristic Karst cultural landscape will be expressed, preserved and revived – in all areas of cultural landscapes in participating countries.

The proposal for reopening existing quarries is based on the [European Landscape Convention](#), as well as on the national legislation of individual participating countries.

In all of these countries, the cultural landscape is defined as an area that is protected on account of its valuable cultural and natural features by prescribing specific regimes. Recording in the cultural heritage register or the record on the state level that is kept by all countries involved in the project is performed by a prescribed procedure that is characteristic of an individual country's law. By recording a particular area or site in the cultural heritage register in Slovenia, Croatia and Bosnia and Herzegovina, as well as the local register in Italy as a Karst cultural landscape, a major

stride would be made towards the improved legal extraction of platy limestone and its direct use in the renovation of cultural heritage buildings.

In Slovenia, the procedure is provided for by the [Cultural Heritage Protection Act](#) and the [Rules on the cultural heritage register](#). The procedure for the proclamation of a cultural landscape as a monument of national importance, monument of local importance or registered heritage is as follows:

1. the petition for recording in the register can be submitted by anyone. If the petition is refused by the competent organisation ([Institute for the Protection of Cultural Heritage of Slovenia](#)), precise reasons for this must be provided;
2. the petition for the proclamation of a monument of local or national importance is drafted by the regional unit of the [Institute for the Protection of Cultural Heritage of Slovenia](#);
3. prior to the proclamation of the monument, owners need to be informed thereof and the plans for this unveiled to the public, whereby they can then submit their opinions, in response to which the institute must provide its position statement;
4. the final proclamation of a monument of national importance is issued by the competent ministry (or several ministries), while the municipality does so for a monument of local importance;
5. the government issues the proposal for the proclamation of protection areas, whereby the briefing of the owners or municipalities is mandatory, and the latter are entitled to issue their opinion on the proclamation. The final proclamation is issued by the ministry (if appropriate, it does so with the consent of other ministries; see also Article 25 of the [Cultural Heritage Protection Act](#)).

In Croatia, the procedure for the protection of the cultural landscape is identical to that in Slovenia. The petition for recording in the register can be issued by anyone, whereby the petition and the relevant documentation are prepared by the relevant expert institution, i.e. the Conservation Department, which is a body affiliated to the Croatian [Ministry of Culture](#). The register is kept by the ministry competent for culture. The mentioned procedure is laid down by the Act on the Protection and Preservation of Cultural Goods ([Zakon o zaštiti i očuvanju kulturnih dobara](#)) and the Rules on the Establishment, Contents and Keeping of the Register of Cultural

Goods of the Republic of Croatia (*Pravilnik o obliku, sadržaju in načinu vodenja Registra kulturnih dobara Republike Hrvatske*). In Italy, the procedure is laid down by the Cultural and Landscape Code, Decree 42 from 2004. The cultural landscape is placed on a level footing with other cultural heritage in Italy and has a separate act regulating it. The petition for the proclamation of a cultural landscape site (or the reopening of a quarry/open pit within a cultural landscape site for the purpose of cultural heritage building renovation) can also be issued by anyone, though an expert (architect) is required for the preparation of the relevant documentation. The petition and the entire documentation are submitted to the regional office that is competent for cultural heritage, which in turn decides on whether to proclaim a site as part of the cultural landscape.

The project group proposes that the area to be protected as a cultural landscape site should be determined first. Areas that would be reasonable to protect as cultural landscape sites are those where proposed potential locations for the future exploitation of platy limestone are located and which have in their vicinity cultural heritage buildings where the obtained building material would be used directly. A petition would be prepared for these areas to be recorded in the cultural heritage register according to the abovementioned procedure that is laid down by the valid legislation of an individual country and the adopted European or international conventions. The petition would be submitted to the competent unit of the relevant service tasked with cultural heritage protection in the region or country, or to the competent ministries (depending on the competences and the organisation of the service in an individual country). The petition should stress the importance of the revitalisation of these quarries for the preservation of cultural heritage in the area, its authenticity and integrity. The permitted excavation of limited amounts of platy limestone should be defined, whereby the stone would be used only for the purpose of preserving cultural heritage (its authenticity and integrity), and the historical importance and sustainable use of selected quarries/sites with platy limestone should be described.

The proclamation of an individual area as a protected cultural landscape site would serve as the basis for the issue of a relevant conservation plan or a plan for the management of a particular area, which should prescribe the use of the material for construction (cultural heritage buildings would be the priority) so as to ensure originality and authenticity and the preservation of local jobs.

The recommendations proposed are:

Conditions for the architectural planning and execution of construction are defined in regulatory provisions of spatial planning acts, whereby they depend on the requirements for monument protection in protected cultural heritage sites, certain buildings and cultural landscape areas. The objectives and principles of spatial management and regulation are usually provided in statutory documents of the relevant administrative level (region, municipality, etc.). Considering that originality and authenticity are not distinct spatial planning values but rather the assumed and recognised values of heritage protection (monuments and cultural landscapes), the competent management level must take suitable steps to require and ensure the use of local material for specified, legally definable purposes.

The requirement for the use of a specific building material that is not laid down according to the established/required procedures, i.e. the recording of a monument in the protected heritage register, the proclamation of a site as a cultural landscape site, etc., may represent interference with the free market and the priority treatment of a particular construction product, which is impermissible.

Regions and municipalities should initiate procedures for the re-instatement of abandoned quarries and other extraction sites in municipal and regional spatial plans and should designate the relevant land use for them, as well as determine the spatial planning conditions for the exploitation of mineral resources.

It would be reasonable to define the possibility of reopening abandoned extraction sites, quarries or pits for the exploitation of platy limestone for the domestic market in national regulations. This would promote the use of an authentic and original material in the immediate surroundings and only for the desired purpose.

Because the extraction of minerals is an activity associated with a particular place, which it also strongly affects, the planning of the use of minerals is always associated with land use allocation planning.

According to the [Mining Act](#), natural stone is not classified as a mineral resource deserving special treatment in Slovenia, as is the case with energy resources that are defined as resources of strategic importance. The Mining Act nevertheless stipulates that the national mining strategy may define the exploitation of certain types of mineral resources that are the only

source or that are not widespread in terms of quality or are required for the realisation of public interests laid down by another act as strategically important for the economic and social development of the Republic of Slovenia. Unique mineral resources that are important for the country or region primarily include unique (autochthonous) natural materials that are a part of the national identity or the cultural and natural heritage and landscape. Despite this wording, natural stone is either treated in context with all other mineral resources or no exceptions apply to it.

In municipal spatial plans, mining site areas are defined with a detailed land use allocation as “areas of the aboveground extraction of mineral resources”. It would therefore be necessary to define in these documents the areas for the extraction of natural stone as potential areas for the exploitation of mineral resources. Abandoned quarries should, upon the amendment and/or supplementation of regulations governing mining, also be designated as potential exploitation sites for the extraction of natural stone for the renovation of buildings recorded in the register of cultural heritage of national or local importance. Platy limestones are a raw material that is incomparably less widespread in the broader project area than the limestones that are used as engineered stone. Natural features or geological conditions should be the primary concern, and only in the subsequent steps should other spatial planning interests (e.g. traffic infrastructure) be considered in the designated areas where platy limestone occurs in confirmed quantities and quality.

In Slovenia and Italy, there are no mining extraction sites to legally extract platy limestone, even though potential sites exist and have been recorded. In Croatia, there are a few legal quarries extracting platy limestone, however a lot of it remains in situ and on the surface as stone gathering is prohibited by modern legislation in the entire project area.

We should touch upon the new regulations in force regulating the collection of waste building material, where it would be reasonable to lay down the option of collecting and sorting natural stone in predetermined landfills, as well as the regimes applying to the use of such material.

We propose that the national regulations prescribe the possibility of re-using natural stone as a building material, mainly for protected buildings and in proclaimed cultural landscapes where authenticity and originality are the primary objectives. The above applies mainly in areas where the exploitation of natural stone in the (currently) abandoned extraction sites is prohibited.

Considering the current conditions relating to the legal status of platy limestone as a building material, which is not recognised in any country as a standardised construction product that could be placed directly on the construction products market, alternative legal possibilities for the use of this material in construction (e.g. re-use) should be established. Since platy limestone does not have a CE certificate, the use of this material should be permitted based on the so-called national technical approval. It is important for a product or material to have a CE certificate because it can only be marketed throughout the EU based on this certificate. The procedure for acquiring the certificate is complex and lengthy. Because platy limestone is neither of sufficient quality nor a desired material for manufacturers to initiate procedures for the acquisition of the CE certificate, we propose the use of the national technical approval. In this case, the material should be available at controlled “construction waste” landfills.

We can conclude based on the studied aspects that the biggest problem in the entire project area is the accessibility of autochthonous building material, i.e. platy limestone. The main obstacle is the extremely strict mining legislation that equalises large commercial quarries extracting large quantities of construction stone annually with small local autochthonous stone quarries or open pits. In addition (or better yet primarily) to the determination and protection of selected areas as cultural landscape sites, we therefore propose an amendment or supplementation of the mining legislation by again including in the Slovenian Mining Act the wording on the one-off extraction of natural stone that was until recently included in [Article 91 of the former mining act](#) (Official Gazette of the Republic of Slovenia, no. 61/2010). By introducing this article again, it would be possible to perform the one-off extraction of natural stone in a particular volume for the purpose of the renovation of educational, sacral and other cultural heritage buildings within a proposed cultural landscape site, i.e. buildings that could not be renovated without such autochthonous materials.

Article 91 of the [Mining Act](#) that is to be reinstated according to our proposal was worded as follows:

(exceptions and special features for the reconstruction or renovation of built structures)

(1) The minister responsible for mining may, at the proposal of the investor intending to reconstruct a particular structure or carry out maintenance

thereon in accordance with the regulations governing the construction of structures, decide that natural stone in the maximum amount of 1000 m³ be extracted for such works in a particular open pit.

(2) The decision referred to in the preceding paragraph is adopted by the minister responsible for mining by way of a decision, against which no appeal is allowed and which is to be served on the investor.

(3) The holder of the mining right shall not pay a mining concession fee for extracting from an open pit the quantity of natural stone extracted pursuant to the decision referred to in the preceding paragraph, while the costs incurred in the extraction shall be borne by the investor.

It would be reasonable to amend the mining legislation in the other three countries in the same or similar manner. This would enable the extraction of platy limestone in a legal way, which would first and foremost contribute to the possibilities for the preservation of autochthonous Karst architecture for future generations.

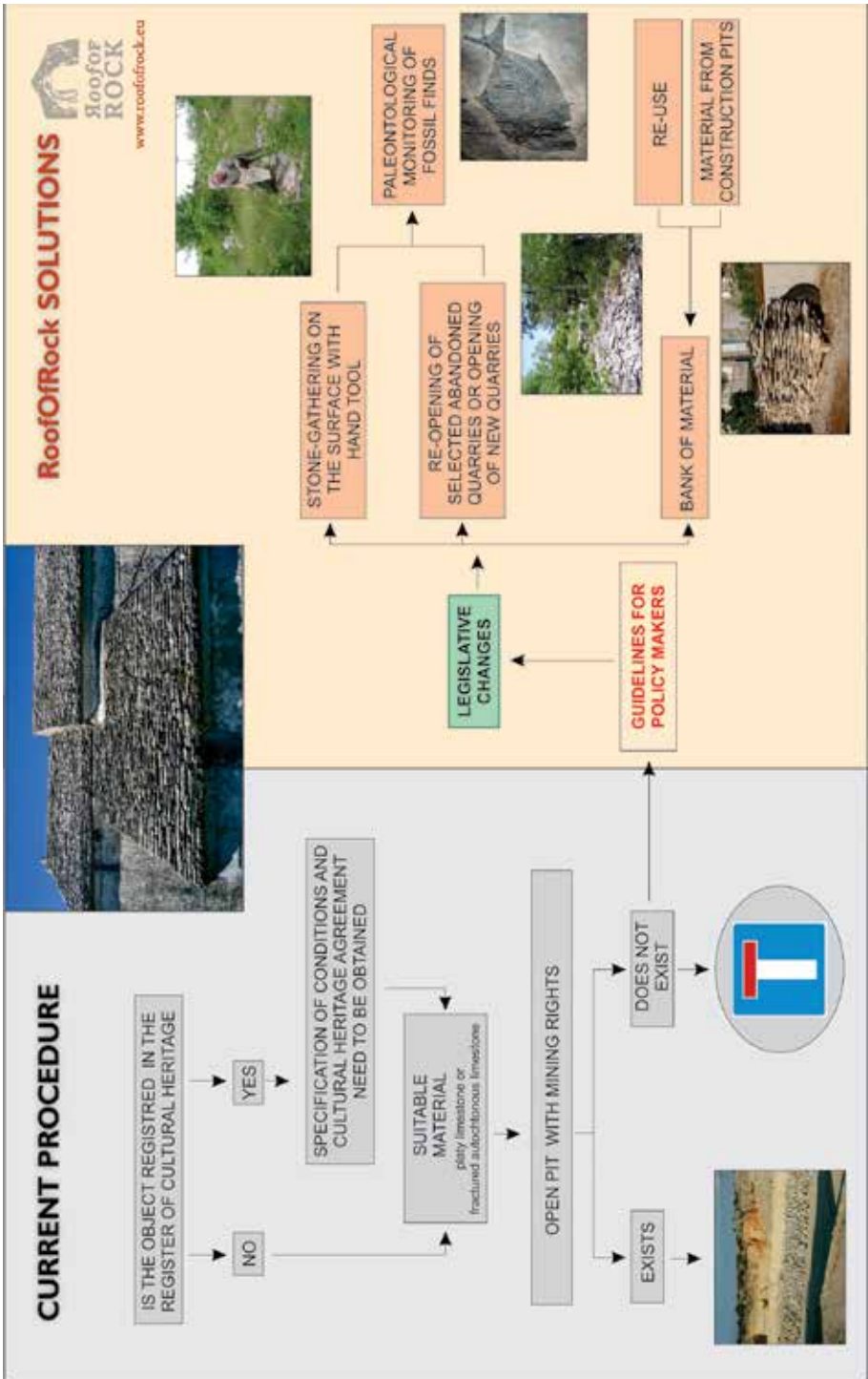

Figure 11. Schematic presentation of the procedure for the renovation of a stone roof with the project recommendations to local authorities for legislative amendments

REFERENCES

- Peternelj, K., Rokavec, D., Pieri, F., Devoto, S., Perissinotto, M., Grabovac, V., Pajčić, M., Alaber, S., Stanič, I., Oven Stanič, M., 2014. Comparative analysis of the existing legislation and standards. 97 str., URL: www.roofofrock.eu

